

For HELP, call La-Z-Boy® Spas at 1.800.465.2933.

L A Z BOY®
S P A S | S I G N A T U R E

OWNER'S MANUAL



La-Z-Boy® Spas
335 Superior Blvd.
Mississauga, ON L5T 2L6
1.800.465.2933
www.lazboyspas.com

Registration of your hot tub is the Lazboy® Spas Retailer's responsibility. Please verify with your Lazboy® Spas Retailer that your hot tub has been registered for your warranty.
Contents subject to change without notice

BJAG

For HELP, call La-Z-Boy® Spas at 1.800.465.2933.

La-Z-Boy® Signature Spas

Owner's Manual

Table of Contents

Safety Information.....	03
Guarantee.....	08
Introduction.....	10
Location and Installation.....	11
Electrical Specifications.....	12
Start Up.....	15
Water Quality.....	20
In-Touch 2000 Controls.....	23
AquaCoustics Surround Sound Stereo.....	29
Optional I-Command System.....	31
Color Coordinated Cover.....	32
Water Management.....	33
Frequently Asked Questions.....	34
Troubleshooting.....	37
Maintenance and Care.....	40
Shutdown / Winterization.....	43
Glossary.....	44
Notes.....	45

Version 1.0

Copyright © 2010 La-Z-Boy® Spas. All rights reserved. No portion of this manual may be reproduced in any manner without express written permission from La-Z-Boy Spas.

La-Z-Boy® is a registered trademark of La-Z-Boy Incorporated and is used under license to 2217044 Ontario Inc.

La-Z-Boy Spas may make product modifications and enhancements. Specifications may change without notice. International products may be configured differently to meet local electrical requirements. Dimensions are approximate.

SAFETY INFORMATION

SAVE THESE INSTRUCTIONS IMPORTANT USER SAFETY INSTRUCTIONS

Your physiological response to hot water is subjective and depends on your age, health, and medical history. If you don't know your tolerance to hot water, or if you get a headache, or become dizzy or nauseous when using your spa / hot tub, get out and cool off immediately.



WARNING

1. CHILDREN SHOULD NOT USE SPAS OR HOT TUBS WITHOUT ADULT SUPERVISION.
2. DO NOT USE SPAS OR HOT TUBS UNLESS ALL SUCTION GUARDS ARE INSTALLED TO PREVENT BODY AND HAIR ENTRAPMENT.
3. PEOPLE USING MEDICATIONS AND/OR HAVING ANY ADVERSE MEDICAL HISTORY SHOULD CONSULT A PHYSICIAN BEFORE USING A SPA OR HOT TUB.
4. PEOPLE WITH INFECTIOUS DISEASES SHOULD NOT USE A SPA OR HOT TUB.
5. TO AVOID INJURY, EXERCISE CARE WHEN ENTERING OR EXITING THE SPA OR HOT TUB.
6. DO NOT USE DRUGS OR ALCOHOL BEFORE OR DURING THE USE OF A SPA OR HOT TUB, TO AVOID UNCONSCIOUSNESS AND POSSIBLE DROWNING.
7. PREGNANT OR POSSIBLE PREGNANT WOMEN SHOULD CONSULT A PHYSICIAN BEFORE USING A SPA OR HOT TUB.
8. WATER TEMPERATURE IN EXCESS OF 38°C (100°F) MAY BE INJURIOUS TO YOUR HEALTH.
9. BEFORE ENTERING THE SPA OR HOT TUB, MEASURE THE WATER TEMPERATURE WITH AN ACCURATE THERMOMETER.
10. DO NOT USE A SPA OR A HOT TUB IMMEDIATELY FOLLOWING STRENUOUS EXERCISE.
11. PROLONGED IMMERSION IN A SPA OR HOT TUB MAY BE INJURIOUS TO YOUR HEALTH.
12. DO NOT PERMIT OR USE ELECTRIC APPLIANCES (SUCH AS LIGHT, TELEPHONE, RADIO OR TELEVISION) WITHIN 1.5M (5FT) OF THIS SPA OR HOT TUB.
13. CHILDREN SHOULD NOT ENTER A HOT TUB WHERE THE WATER TEMPERATURE EXCEEDS BODY TEMPERATURE (37°C / 98.6°F).
14. DO NOT ALLOW CHILDREN TO SUBMERGE THEIR HEAD UNDER WATER.
15. NEVER OPERATE THE HOT TUB PUMP AT HIGH SPEED WITHOUT HAVING ALL SUCTION AND RETURN LINES OPEN.
16. ALWAYS KEEP THE HARDCOVER INSTALLED AND LOCKED WHEN THE HOT TUB IS NOT IN USE.
17. TEST THE GFCI (GROUND FAULT CIRCUIT INTERRUPTER) MONTHLY.
18. POST EMERGENCY PHONE NUMBERS FOR POLICE, FIRE DEPARTMENT, AND AMBULANCE AT THE NEAREST PHONE.
19. TO REDUCE THE RISK OF INJURY
 - THE WATER IN A SPA SHOULD NEVER EXCEED 40°C (104°F). WATER TEMPERATURES BETWEEN 38°C (100°F) AND 40°C (104°F) ARE CONSIDERED SAFE FOR A HEALTHY ADULT. LOWER WATER TEMPERATURES ARE RECOMMENDED FOR YOUNG CHILDREN AND WHEN SPA USE EXCEEDS 10 MINUTES.
 - SINCE EXCESSIVE WATER TEMPERATURES HAVE A HIGH POTENTIAL FOR CAUSING FETAL DAMAGE DURING THE EARLY MONTHS OF PREGNANCY, PREGNANT OR POSSIBLY PREGNANT WOMEN SHOULD LIMIT SPA WATER TEMPERATURES TO 38°C (100°F).
 - BEFORE ENTERING A SPA, THE USER SHALL MEASURE THE WATER TEMPERATURE SINCE THE TOLERANCE FOR WATER TEMPERATURE-REGULATING DEVICES VARIES.
 - THE USE OF ALCOHOL, DRUGS, OR MEDICATION BEFORE OR DURING SPA USE MAY LEAD TO UNCONSCIOUSNESS, WITH THE POSSIBILITY OF DROWNING.
 - OBESE PERSONS AND PERSONS WITH A HISTORY OF HEART DISEASE, LOW OR HIGH BLOOD PRESSURE, CIRCULATORY SYSTEM PROBLEMS OR DIABETES SHOULD CONSULT A PHYSICIAN BEFORE USING A SPA.
 - PERSONS USING MEDICATION SHOULD CONSULT A PHYSICIAN BEFORE USING A SPA SINCE SOME MEDICATION MAY INDUCE DROWSINESS WHILE OTHER MEDICATION MAY EFFECT HEART RATE, BLOOD PRESSURE AND CIRCULATION.

For HELP, call La-Z-Boy® Spas at 1.800.465.2933.

SAVE THESE INSTRUCTIONS

IMPORTANT SAVE THESE INSTRUCTIONS

Your physiological response to hot water is subjective and depends on your age, health, and medical history. If you don't know your tolerance to hot water, or if you get a headache, or become dizzy or nauseous when using your hot tub, get out and cool off immediately.



CAUTION

1. MAINTAIN WATER CHEMISTRY IN ACCORDANCE WITH THE MANUFACTURER'S INSTRUCTIONS.



DANGER

1. RISK OF ACCIDENTAL DROWNING. EXTREME CAUTION MUST BE EXERCISED TO PREVENT UNAUTHORIZED ACCESS BY CHILDREN. TO AVOID ACCIDENTS, ENSURE THAT CHILDREN CAN'T USE THE SPA UNLESS THEY ARE SUPERVISED AT ALL TIMES.
2. RISK OF INJURY. THE SUCTION FITTINGS IN THIS SPA ARE SIZED TO MATCH THE SPECIFIC WATER FLOW CREATED BY THE PUMP. SHOULD THE NEED ARISE TO REPLACE THE SUCTION FITTINGS OR THE PUMP, BE SURE THAT THE FLOW RATES ARE COMPATIBLE. NEVER OPERATE THE SPA IF THE SUCTION FITTINGS ARE BROKEN OR MISSING. NEVER REPLACE A SUCTION FITTING WITH ONE RATED LESS THAN THE FLOW RATE MARKED ON THE ORIGINAL SUCTION FITTING.
3. RISK OF ELECTRIC SHOCK. INSTALL AT LEAST 1.5M (5FT) FROM ALL METAL SURFACES. AS AN ALTERNATIVE, A SPA MAY BE INSTALLED WITHIN 1.5M (5FT) OF METAL SURFACES IF EACH METAL SURFACE IS PERMANENTLY CONNECTED BY A MINIMUM 8 AWG (8.4 mm²) SOLID COPPER CONDUCTOR TO THE WIRE CONNECTOR ON THE TERMINAL BOX THAT IS PROVIDED FOR THIS PURPOSE.
4. RISK OF ELECTRIC SHOCK. DO NOT PERMIT ANY APPLIANCE, SUCH AS A LIGHT, TELEPHONE, RADIO, OR TELEVISION, WITHIN 1.5M (5FT) OF THE SPA.

HYPERTHERMIA

Since your hot tub can be set to reach temperatures of 40°C (104° F), users should be aware that extended submersion in water that exceeds normal body temperature can lead to hyperthermia.

The causes, symptoms and effects of hyperthermia may be described as follows:

Hyperthermia occurs when the internal temperature of the body reaches several degrees above the normal body temperature of 37°C (98.6°F). The symptoms of hyperthermia include drowsiness, lethargy, and an increase in the internal temperature of the body. The effects of hyperthermia include:

- Unawareness of impending hazard
- Failure to perceive heat
- Failure to recognize the need to exit the hot tub
- Physical inability to exit the hot tub
- Fetal damage in pregnant woman
- Unconsciousness resulting in the danger of drowning

If you sense any of the symptoms of hyperthermia, safely exit the hot tub immediately.

WARNING



THE USE OF ALCOHOL, DRUGS OR MEDICATION CAN SIGNIFICANTLY INCREASE THE RISK OF FATAL HYPERTHERMIA.

IMPORTANT ELECTRICAL SAFETY INSTRUCTIONS

SAFETY COMES FIRST WHEN INSTALLING & USING THIS ELECTRICAL EQUIPMENT, BASIC SAFETY PRECAUTIONS MUST ALWAYS BE FOLLOWED!

1. **READ AND FOLLOW ALL INSTRUCTIONS.**
2. Electrical installation must be completed by a qualified electrician in accordance with all National, Regional and Local Codes and Regulations in effect at the time of installation.
3. **Connect only to a dedicated circuit protected by a class "A" two-pole ground fault circuit interrupter (GFCI).**
4. Use copper conductors only.
5. The hot tub equipment and all electrical plugs, outlets and lights within 1.5m (5 ft) of the unit must be GFCI protected. Consult your electrician or local electrical authority for further details.
6. A green colored terminal or a terminal marked "G", "GR", "Ground", or "Grounding" is located inside the supply terminal box or compartment. To reduce the risk of electric shock, this terminal must be connected to the grounding means provided in the electric supply service panel with a continuous copper wire equivalent in size to the circuit conductors supplying the equipment.
7. At least two lugs marked "**BONDING LUGS**" are provided on the external surface or on the inside of the supply terminal box or compartment. To reduce the risk of electric shock, connect the local common bonding grid in the area of the hot tub to these terminals with an insulated or bare copper conductor not smaller than No. 6 AWG (Canada/Europe) / No. 8 AWG (USA).
8. All field installed metal components such as rails, ladders, drains or other similar hardware within 3m (10 ft) of the hot tub shall be bonded to the equipment grounding bus with copper conductors not smaller than No. 6 AWG.
9. **SAVE THESE INSTRUCTIONS.**

WIRE SIZES

NORTH AMERICA

- The minimum wire size for systems that require a 40A GFCI is #8/3 conductor with ground. (also referred to as #8 gauge / 4 conductor).
- The minimum wire size for systems that require a 50A or 60A GFCI is #6/3 conductor with ground (also referred to as #6 gauge / 4 conductor).

IMPORTANT NOTE:

- This guide is for standard installations where the wire run is 15m (50 ft) or less. For longer runs, consult a qualified electrician.

SAFETY SIGN

Safety Sign Must Be Posted – The orange **WARNING** sign like the one shown is packed with your new spa/hot tub. This sign must be posted in a prominent place in close proximity to the spa installation site immediately upon completion of spa installation.

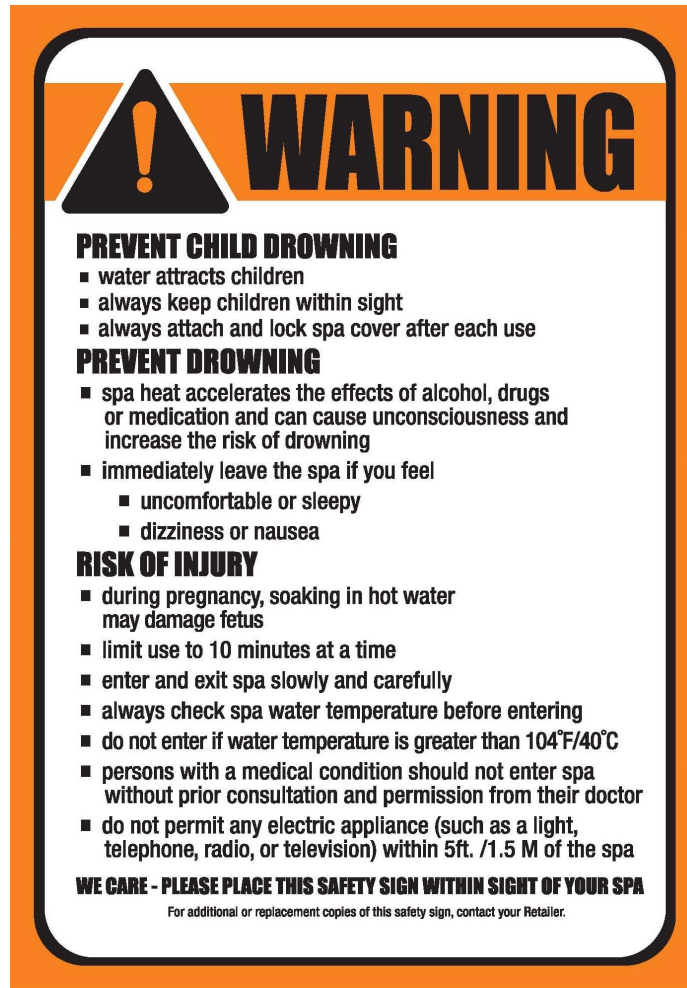

Important: It is extremely important that this sign be permanently placed in clear view of persons using the spa / hot tub. Occasional spa / hot tub users may not be aware of some of the dangers hot water poses to pregnant women, small children, seniors, and people under the influence of alcohol. If you did not receive a warning sign or your sign has become damaged, please call your local dealer for a replacement.

For HELP, call La-Z-Boy® Spas at 1.800.465.2933.

Dealer:

Date Purchased: _____
Company: _____
Address: _____
Telephone: _____

Installer:

Date Installed: _____
Company: _____
Address: _____
Telephone: _____

Spa:

Date Delivered: _____
Model: _____
Color: _____
Serial Number: _____

Your unique spa / hot tub serial number is located on a data plate outside the cabinet at ground level directly below the topside control panel. When calling for service, please have your serial number on hand.

For HELP, call La-Z-Boy® Spas at 1.800.465.2933.

La-Z-Boy® Spas Guarantee

Since 1927, La-Z-Boy has been building some of the finest quality products for the home. We are confident that you will enjoy the most comfortable spa ownership experience possible. Our no nonsense, no fine print Guarantee provides complete ownership coverage for complete comfort and peace of mind.

10-Year Structural Guarantee

La-Z-Boy Spas Signature and Premier Spas guarantee to the original owner that the structural fiberglass resin composition of your Comfort Fit Shell will not leak and the structural support system of the spa will be free from defects in materials and workmanship for ten years. If a failure occurs, we will supply the materials and technical labor for the repair.

5-Year Acrylic Guarantee

La-Z-Boy Spas guarantees that Premier and Signature Collection Spas with a cross linked acrylic finish will be free from defects in materials and workmanship for five years. If a failure occurs, we will supply the materials and technical labor for the repair.

100% Component Guarantee

La-Z-Boy Spas guarantees the following factory installed components where applicable: In-Touch Electronic Controls, Personal AquaFlex Control(s), Comfort Massage Pump(s), AquaFlex Massage Pump(s), Mini 24/7 Circulation Pump, Heating System, LED Mood & Safety Lighting, LED Accent Lighting, Everlast / Envirocare Cabinet, Ozone Water Purifier, Waterfall, AquaClear Salt Water System, iCommand, internal and external plumbing and light lenses, will be free from defects in materials and workmanship for three years. If a failure occurs we will supply the materials and technical labor for the repair. The ozone generator uses a consumable corona discharge chip that is not covered under the guarantee.

100% AquaCoustics / AquaVision Guarantee / AquaClear Guarantee

La-Z-Boy Spas guarantees that the optional AquaCoustics, AquaVision and AquaClear Salt Water System electronic systems will be free from defects in materials and workmanship for one year. If a failure occurs, we will supply the materials and technical labor for the repair.

100% Exchange Guarantee

La-Z-Boy Spas guarantees that the factory supplied Color Coordinated Cover, Comfort Massage Jet Inserts, Filter Lids, Comfort Rest Pillows, Skimmer Covers and Floating Remote Controls will be free from defects in materials and workmanship for one year. If a failure occurs, you can exchange the failed component at your local La-Z-Boy Spas retail store.

100% Guarantee Transfer Option

The remaining portion of the La-Z-Boy Spas Guarantee is transferable to a new owner for a fee of \$299, once in the life of the guarantee. It is the new owner's responsibility to contact their local La-Z-Boy Spa representative to arrange for a customer-paid installation inspection of the spa to activate the guarantee transfer. The transfer fee, spa serial number and inspection sheet must be received by La-Z-Boy Spas office within 60 days of the ownership transfer to be valid.

See the reverse side of this Guarantee for simple and easy to understand Performance Standards, Disclaimers, Limitation and Legal Rights. These guidelines will ensure that you receive the best service and customer support for your La-Z-Boy Spa.

La-Z-Boy is a trademark of La-Z-Boy Incorporated and is used under license to 2217044 Ontario Inc.

LA Z BOY®
S P A S

Live life Comfortably™

La-Z-Boy® Spas Guarantee

Performance Standards

To receive service from a qualified La-Z-Boy® Spa service representative, your spa must be registered and you may be asked to provide an original bill of sale. Our La-Z-Boy Spa Guarantee starts from the original date of delivery. You may be assessed a reasonable travel charge for service at your home. It is the spa owner's full responsibility to provide unencumbered access to the equipment for service, removal, and/or re-installation of the spa for required repairs.

If La-Z-Boy Spas determines that the repair of the spa is not feasible it reserves the right to provide a replacement spa equal in value to the original purchased price. In this case the owner is responsible for expenses including removal, shipping and re-installation of the existing or replacement spa. Upon replacement of a spa, the guarantee will cover the remaining portion of the existing guarantee from the original installation date.

The guarantee does not cover fading from natural aging and/or damage from excessive chemical use on all spa finishes and fixtures. La-Z-Boy Spas installed for commercial applications are excluded from all Guarantee coverage. The La-Z-Boy Spas Guarantee can not anticipate, nor does it cover, damage or failure that has occurred as a result of product abuse, accidents, power disturbances, vandalism, acts of God or nature and other causes which are out of any manufacturer's control.

All La-Z-Boy Spas must be used, installed and maintained as directed by the supplied Owner's Manual to receive guarantee coverage. This La-Z-Boy Spas Guarantee is valid only in the country of purchase. Service after the sale is the responsibility of the dealer from whom you purchased your La-Z-Boy Spa. All Guarantees are registered online by your La-Z-Boy Spa dealer.

Disclaimers

La-Z-Boy Spas and its representatives shall not be liable for any injury, loss, cost or other damage, whether incidental or consequential, arising out of any defect covered by this Guarantee, including, without limitation, loss of use of the spa and cost for removal of defective product, even if La-Z-Boy Spas has been advised of the possibility of such damage. The liability of La-Z-Boy Spas under this Guarantee, if any, shall not exceed the original amount paid for the defective product. Coverage under this Guarantee shall commence as of the date of installation or if not specified, the original date of purchase and the duration of such coverage shall not extend for any reason whatsoever beyond the stated time periods. These disclaimers shall be equally applicable to any service provided by La-Z-Boy Spas or its designated representatives.

Limitations

This Limited Guarantee takes the place of all other warranties, express or implied, in fact or at law, including implied warranties of merchantability and fitness for a particular purpose. All Guarantee service must be performed by La-Z-Boy Spas or its designated representative using authorized parts. No agent, dealer, distributor, Service Company or other party is authorized to change, modify or extend the terms of this Limited Guarantee in any manner whatsoever.

Legal Rights

This Guarantee gives you specific legal rights. You may also have other rights which vary from state to state country to country. Some states and provinces do not allow limitations on how long an implied Guarantee lasts, so this limitation may not apply to you.

La-Z-Boy is a trademark of La-Z-Boy Incorporated and is used under license to 2217044 Ontario Inc.

L A Z B O Y
S P A S

Live life Comfortably™

INTRODUCTION

Your choice of a La-Z-Boy® Signature Spa indicates that you are devoted to excellence. The management and staff appreciate your patronage and take pride in the tradition of quality spas / hot tubs that our company represents.

To properly acquaint yourself with your spa / hot tub, we suggest that you take time to read through this manual before hook up and operation. Doing so will familiarize you with the important operating and safety procedures, thereby ensuring an enjoyable experience right from the start.

If you need any more information than this manual provides, feel free to call your local dealer or visit our web site at www.lazboyspas.com.

NOTICE



This manual was written to ensure the proper use and installation of your spa / hot tub. Any modifications to the procedures outlined in this manual may result in voiding your guarantee.

This manual and its contents are subject to change without notice. Although we have prepared this manual as accurately as possible, we are not liable for errors or omissions; loss, injury, or damages caused by improper installation; or use of spa / hot tub (improper or otherwise).

Notes: _____

LOCATION AND INSTALLATION

Proper planning is an important consideration when installing your new spa / hot tub. Site selection is a critical step and requires serious thought. Planning ahead makes the installation process easier. The following information is provided to assist you in site preparations.

1. Always comply with local building codes and obtain any necessary permits. You may also need to consult with an engineer to address your specific design needs.
2. Contact an electrician to assess your electrical needs, install wiring, and assure a safe operation.
3. Position your spa / hot tub with proper access to water, drainage, and electricity.
4. Place your spa / hot tub on a uniform solid, flat surface designed to properly support its weight. For external installations, a 4-inch (10 cm) thick cement pad suffices.
5. For internal installations, check the load carrying capabilities of the floor on which the spa will reside. Most homes meet the requirement of 250 pounds per square foot.
6. Assure that your spa / hot tub will fit into the space you have chosen and the delivery route will accommodate its large size.
7. Provide adequate ventilation for the humidity created by your spa / hot tub. In most cases, the Color Coordinated Cover is sufficient.
8. Protect the pump and all equipment from the weather by ensuring the cabinet panels are secure at all times.
9. Allow 36 inches (1 meter) of unobstructed access to all sides of your spa / hot tub for normal servicing. Your spa / hot tub is not designed to be recessed in the ground or in a deck.
10. Consider positioning your spa / hot tub out of or adequately protecting it from the wind. Just as people can get cold on cool / windy days so can your spa / hot tub. Windy environments can significantly increase operating costs.
11. Consider using an insulating pad. In cold climates, the ground can rob heat from the spa / hot tub and increase your operating costs. Consider using a suitable, outdoor insulating pad in such environments.

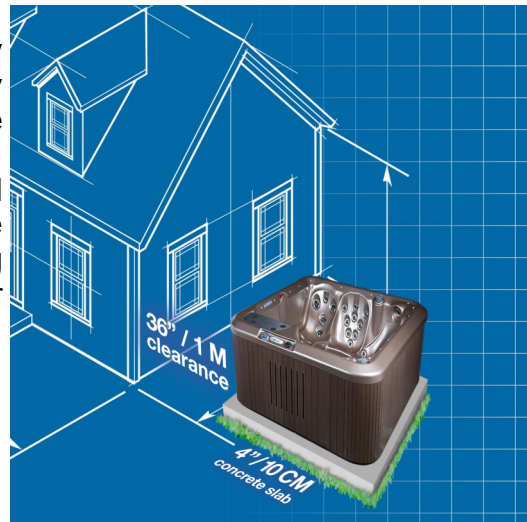

Figure 1 – Clearances and Support

ELECTRICAL SPECIFICATIONS

Important: Qualified and licensed electricians must perform all electrical hookups. The following specifications must be followed in order to ensure proper performance and safety.

WARNING



Starting an incorrectly wired spa / hot tub could cause severe damage to the mechanical equipment or even bodily harm. Have your licensed electrician verify GFCI wiring with the schematics on pages 13-14 prior to starting the spa / hot tub or call your local dealer.

CAUTION



Failure to abide by specifications listed may result in damage to the equipment and will void the warranty.
Test the GFCI before each use of the spa / hot tub.

All spa / hot tubs must be wired with a GFCI breaker (or according to IEEE wire regulations for export models). Failure to do so will cause equipment damage and will not be covered under your guarantee. All spa / hot tubs must be protected with an over current protective device with built-in GFCI in the service panel.

Volts (V)	Freq. (Hz)	Phase	Rating (A)	GFCI (A)	Wire size from GFCI to Main Panel*	# of Terminals on plug
240	60	1	32	40	8-3 plus ground (less than 50')	4
240	60	1	40	50	8-3 plus ground (less than 50') 6-3 plus ground (more than 50')	4

Table 1 – Wire Size Chart

IMPORTANT NOTE: (FIGURE 2)

The following dimensions can be used to determine the proper location of submerged conduits in concrete slab installations. The dimensions are made from the outside of the spa / hot tub frame with the access for panels removed. The topside control panel is shown at the bottom of the diagram as a reference.

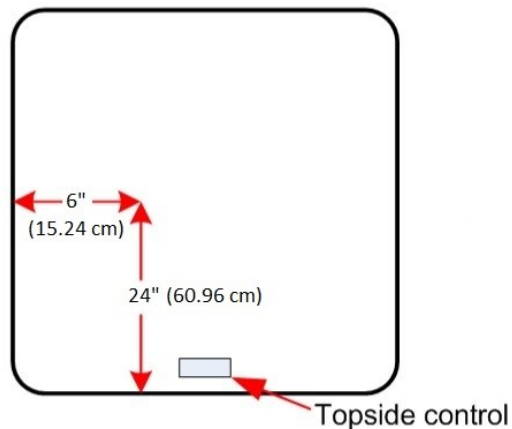

* Use only solid copper wire.

FIGURE 2: ELECTRICAL CONDUIT LOCATION

WARNING



Disconnect the electrical power before servicing. Before obtaining access to terminals, all supply circuits must be disconnected.

Parts with extra low voltage (not exceeding 12V) must be inaccessible to a person in the spa / hot tub. Earthed appliances must be permanently connected to fixed wiring. Parts incorporating electrical components must be located or fixed so that they cannot fall into the spa / hot tub. Means for disconnection must be used with fixed wiring configurations in accordance with local wiring rules.

IMPORTANT: To allow the GFCI to function properly, connect the white Neutral wire from the spa / hot tub to the Neutral terminal on the GFCI breaker, not the Neutral bus bar in the GFCI breaker box. An improperly connected Neutral causes the GFCI breaker to trip.

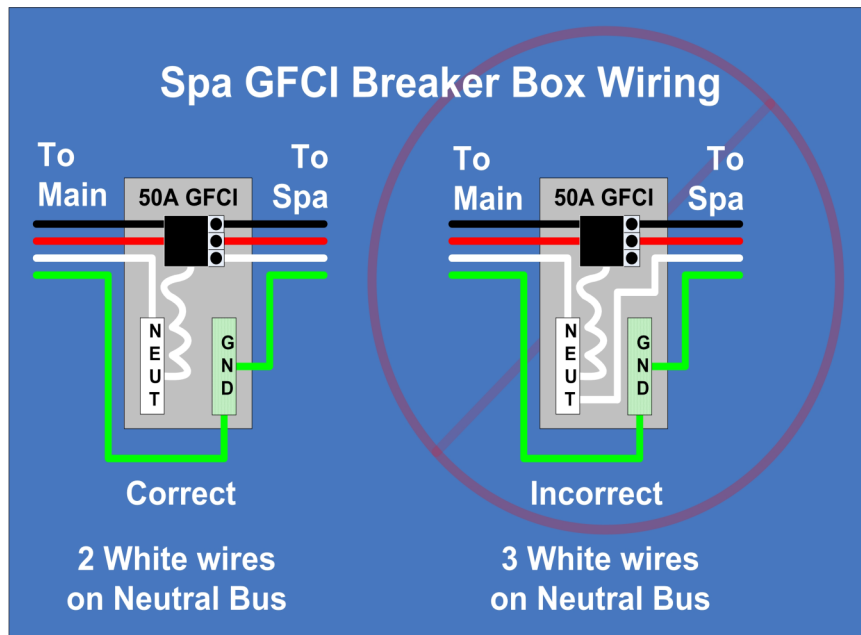

Figure 3 - GFCI Wiring

For HELP, call La-Z-Boy® Spas at 1.800.465.2933.

IMPORTANT: Installation, including selection of conductor size and type, must be performed by a qualified electrician in accordance with the National Electrical Code or the Canadian Electrical Code, and all federal, state and local codes and regulations in effect at the time of installation.

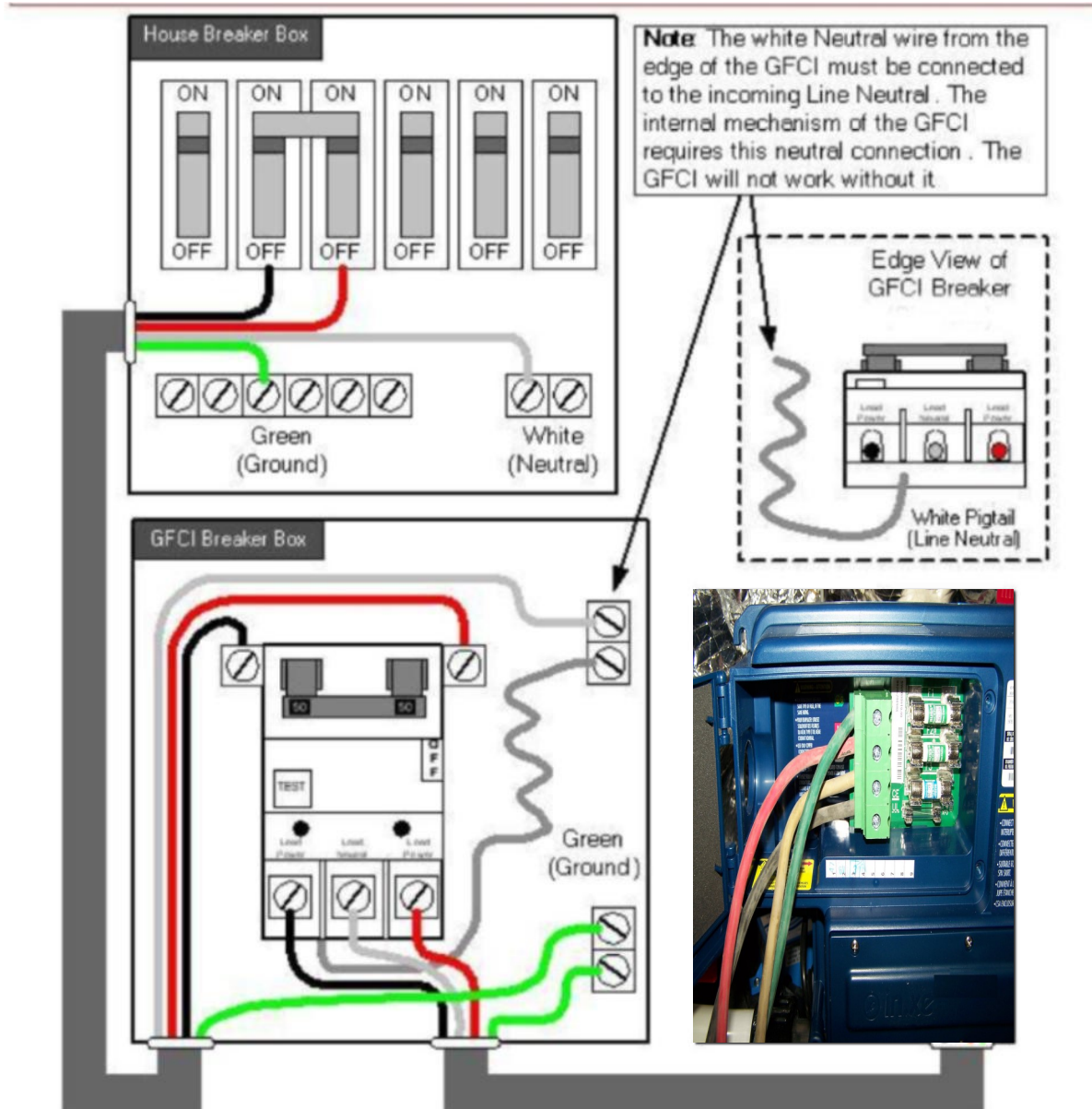

Figure 4 - U.S. and Canada Wiring Diagram

See wire size chart on page 12.

STARTUP

Important: Read these step-by-step startup procedures before using your spa / hot tub. Failure to do so may result in damage to the equipment and may void your guarantee

Note: If you are unsure of any of the above startup procedures, please call your local dealer for assistance. For best results, read each step in its entirety before proceeding.

CAUTION



Running the spa / hot tub pump dry (without water running through it) can cause IMMEDIATE damage and will void the Guarantee. Be sure that the spa / hot tub is installed properly in accordance with the instructions in this manual.

Refer to the following picture for an explanation of your spa / hot tubs controls, components, and technical terms.

Note: Not all models have all features and components.

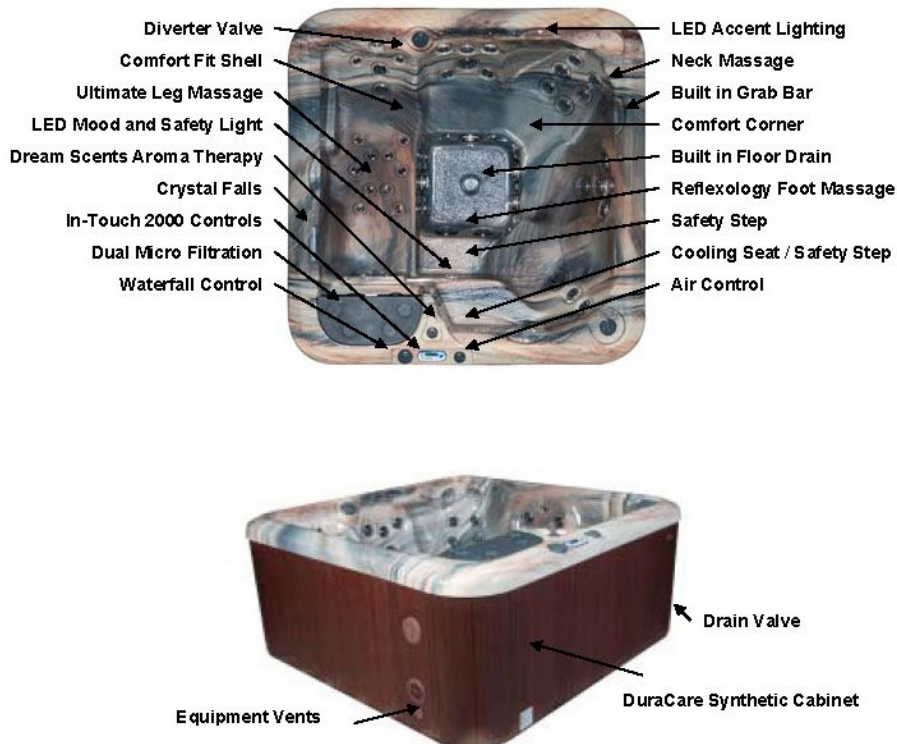

Figure 5 - Callouts

BEFORE ADDING WATER

Before adding water, go through these simple steps now to prevent common issues when setting up your spa / hot tub for the first time. Verify that the following have all been rechecked.

1. Turn off all power at the main breaker panel.
2. Open the front panel to access the internal components.
3. Check that all gate valves are opened to the heater and all pumps.
4. Check that there are no obvious signs of loose wires or broken pipes.
5. Check that the two heater unions are tight.

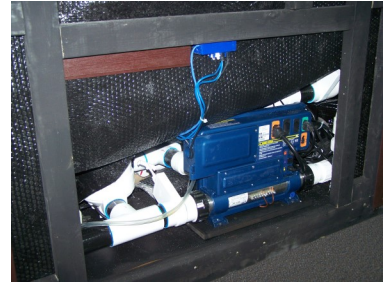

Figure 6 - Valve Open/Closed



CAUTION:

Do not use a wrench.
Over-tightening may cause damage to unions and gaskets, which will not be covered the Guarantee.



Figure 7 - Unions Tight

6. Check that the unions on all pumps are tight.
7. Clean out any foreign debris from within the service access area or inside of the spa / hot tub itself.
8. With the drain open and filters removed, thoroughly rinse out the spa / hot tub with warm water until the drained water runs clear. Run water through the filtration canister and jet lines to remove any incidental dust, dirt, and debris that may have accumulated during shipment or installation. Drain all water completely.
9. Make sure that the spa / hot tub drain valve is closed and the cap is on tight.
10. Install the filters in the filtration canister.
11. Check that all of the jets are open (turned full counter-clockwise).
12. Now is the best time to clean and polish the surfaces of your spa.

FILLING YOUR SPA

Now it's time to fill your spa / hot tub with water. Do not turn on the electricity until the spa / hot tub is completely filled. To properly fill your spa / hot tub:

1. Make sure that the filters (in the filtration canister) are gently screwed into place. Turn them clockwise until they stop, being careful not to over-tighten them (this avoids cracking the filter).
2. Connect a standard garden hose to a faucet with regular cold tap water (not softened water or hot water).



Figure 8 - Filtration Canister

CAUTION



The water from your hot water tank should not be used to fill the spa / hot tub.

3. Put the pre-filter* on the other end of the hose, point the pre-filter into a suitable drain, turn on the water, and allow any sediment to be flushed down the drain. Once the water stream runs clear, turn off the hose.
4. Put the pre-filter (if equipped) into the filtration canister and turn on the hose.
5. **Fill slowly.** If too much water pressure is used, foaming water can force air into the pipes and cause startup problems.

* Pre-filters are available at most dealers

Important: To ensure that the pump is properly primed, **fill the spa / hot tub through the filter area only.**

6. Fill the spa / hot tub until the water level is about 6" below the top lip of the spa / hot tub. Do not over fill.

Note: Every person entering a spa / hot tub displaces a given volume of water, so adjust water level to the number of people regularly using the spa / hot tub.

Turn off the hose and check again for any small leaks.

OPERATIONAL CHECKS

CAUTION



Do not turn on any pump until your spa is properly filled with water. Running any pump without water in your spa can cause IMMEDIATE damage, which is not covered by the guarantee!

By now you have rechecked your spa / hot tub mechanical connections and filled it with water to about 1" above all jets by adding cold tap water through the pre-filter (if equipped). Turn on power to the spa / hot tub at the main breaker panel and test the operation of the electrical system. If you encounter a problem, please reference the troubleshooting guide.

Turn on the breaker and test the operation of the Ground-Fault Circuit Interrupter (GFCI) breaker by pushing the small button. This should automatically trip the spa / hot tub circuit breaker. Only if pushing this button successfully trips this circuit breaker should you reset this breaker and proceed to the initial start up procedure.

DANGER



If this breaker does not trip, immediately call your electrician. Do not use your spa / hot tub!

INITIAL START UP PROCEDURE

- 1) Ensure the circuit breaker to the spa / hot tub is off.
- 2) Rotate all the jets in the spa /hot tub to the fully open position.
- 3) Ensure that all of the gate valves are open. The gate valve is open when the handle is fully extended up and clipped in place. Models with 1 pump will include 2 valves and models with 2 pumps will include 4 valves. Note: a circulation pump (when installed) will include an additional 2 valves.
- 4) To prevent the possibility of leakage in the equipment bay, ensure the pump unions are tight.
- 5) Close and cap the hose bib. This is used for draining the spa / hot tub.
- 6) Fill the spa / hot tub until the water level is about 6" below the top lip of the spa / hot tub. Do not overfill.

For HELP, call La-Z-Boy® Spas at 1.800.465.2933.

7) Turn on the circuit breaker. Set the desired temperature by using the up or down keys.

8) Push the jets 1 keypad to turn on the low speed pump. Check to ensure water is coming from some of the jets. If the water is not flowing out, open the pump union slightly to release trapped air. Close the union when the pump pushes water out of the jets. Push the jets 1 keypad and the pump will turn on high speed. Observe closely to ensure adequate water flow. Push the jets 2 key pad (if equipped) and pump 2 will turn on high speed. Observe to ensure adequate water flow. If there is no water flow through the jets, the pumps need to be primed.

9) Re-attach the equipment access panel.

10) Ensure proper water chemistry only after completing the above steps.

11) To conserve energy and ensure your spa / hot tub is ready for use, place the color coordinated cover securely on the spa.

CAUTION



If water does not flow from the jets after 2 minutes, turn power off at the main panel and bleed air from the system. Turn power on again. Sometimes momentarily turning a pump off/on will prime it. Only do this four times.

NOTE:

In order to prevent damage to your pillows caused by the gassing effect of the chemicals, we do recommend to remove them when the spa is not in use. By removing them you will extend considerably the life length of your pillows. We do design ours pillows to be removed easily in order to make sure they will not remain in the spa when it's not in use.

WATER QUALITY

Note: Perform water quality testing weekly and whenever your water is changed (or when your spa / hot tub is first filled).

Once your spa / hot tub reaches 95°F, properly adjust the chemistry of your spa / hot tub water by testing it with good quality test kits and adjusting levels as needed.

Note: Balancing and sanitization products are **not included**.

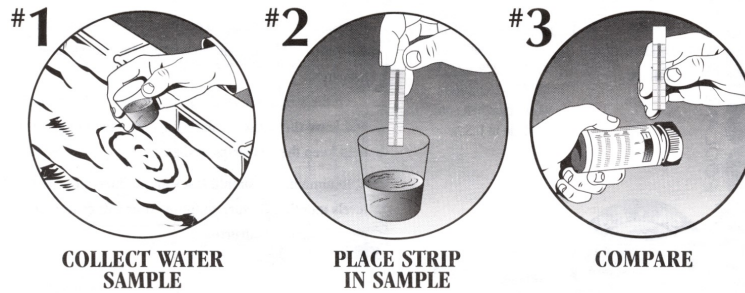

Figure 9 – Typical Test Strip Usage

TOTAL ALKALINITY

Important: Total Alkalinity (TA) is the first parameter you should balance when making routine adjustments to your water.

Once your water temperature reaches 95°F, test the total alkalinity of your spa / hot tub water with a good quality test kit. Maintain a total alkalinity level of **80 to 120 ppm**.

Total alkalinity is the measure of alkaline buffers in your water. These buffers protect the water against sudden changes in pH. Total alkalinity is considered the key to water balance.

When the total alkalinity is too low, add sodium bicarbonate. If the total alkalinity is too high, you can lower it by using muriatic acid or sodium bisulfate.

ACID ALKALINE BALANCE (pH)

Test the pH of your spa water with a good quality test kit. Maintain a pH level of **7.2 to 7.8**.

A balanced pH promotes bathing comfort and prevents corrosion, staining, scaling, or cloudy water.

If the measured pH is too low, add soda ash to the spa water. If the pH is too high, add sodium bisulfate to the spa water. Follow the directions on the manufacturer's label and make small changes. Circulate the water for 20 minutes before retesting.

HARDNESS LEVEL

Once your pH level is proper, test the hardness level of your water with a good quality test kit. Maintain a hardness of **200 to 400 ppm (mg/L)**.

A balanced hardness level helps prevent corrosion and scaling.

If the measured hardness level is too low, add calcium chloride to the water. If the hardness level is too high, partially drain and refill your spa / hot tub with cold tap water. Follow the directions on the chemical manufacturer's label and make small changes.

Note: If the hardness level is higher than 400 ppm (mg/L) when initially filling your spa / hot tub, the hardness level of your tap water may be too high. If so, partially drain your spa / hot tub. Use a good quality pre-filter to the supply line when refilling it.

SANITIZATION, CHLORINE / BROMINE

Once your hardness level is proper, it is imperative that you do not use the spa / hot tub until there is a minimum reading of chlorine or bromine in the water. Maintain a chlorine or bromine level of **3 to 5 ppm (Mg/L)**

Chlorine and bromine are available from your dealer in tablet and granular form.

Tablets or granular products should never be added directly to the spa / hot tub. Damage and discoloration to the surface may occur. Tablets should always be placed in a tablet dispenser (not included) and the tablet dispenser then placed into the spa / hot tub water.

Granular products should be applied to the spa / hot tub water in strict accordance with the manufacturer's recommendations. Never apply granular chlorine or bromine products directly to the spa water.

For HELP, call La-Z-Boy® Spas at 1.800.465.2933.

WATER QUALITY SUMMARY

The following table summarizes the desired water quality properties your spa / hot tub should have:

Test	Desired Value
Total Alkalinity	80 to 120 ppm (mg/L)
pH	7.2 to 7.8
Hardness	200 to 400 ppm (mg/L)
Bromine	3 - 5 ppm (mg/L)
Chlorine	3 - 5 ppm (mg/L)

Table 2 – Water Quality Desired Values

IN-TOUCH 2000 ELECTRONIC CONTROLS

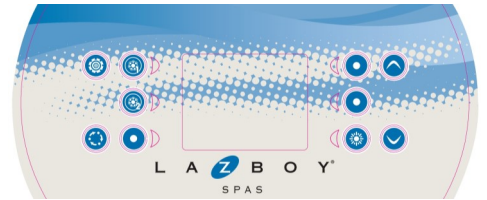
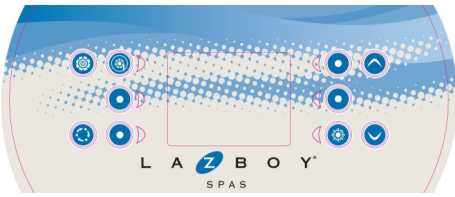

INITIAL START-UP

Before applying voltage to power-up your hot tub, it is very important that you understand the sequence of events that occur when the system is activated in order that the pump(s) can be primed efficiently and damage to the system can be avoided.

At initial power-up, the system will indicate the following message.



The keypad does not store the date and time so when the system starts up after a loss of power a message will prompt you to reprogram the time and date.

PROGRAMMING THE DATE AND TIME



Here you can adjust the time format (AM/PM or 24h), day of the week and time. Use the arrows to choose the setting that you want to adjust and select it by pressing the Light key. Use the arrow buttons to change the parameters and the Light key to move between parameters. Pump 1 will take you back to the main Settings menu.



TEMPERATURE CONTROL FUNCTIONALITY AND ADJUSTMENT



After you exit the programming mode your hot tub will automatically heat to the factory preset default temperature of 38°C (100°F).

The temperature shown at the top of the screen is the current water temperature. Use the UP and DOWN buttons to set the desired temperature.

The set point will appear in the blue at the bottom. After 3 seconds without any change to the set temperature value, the keypad will resume the normal display of messages.

When the set value is lower than the current temperature "Cooling to XX" will appear. When the value is set higher than the current temperature, "Heating to XX" will be indicated.

PUMP 1 FUNCTION

Press this pad to activate the pump

- 1st press – low speed (**icon rotates slow**)
- 2nd press – high speed (**icon rotates fast**)
- 3rd press – turns off

PUMP AUTOMATIC TIME-OUT

- High speed** – 15 minutes
- Low speed** – 15 minutes

PUMP 2 FUNCTION (if included)

Press this pad to activate the pump

- 1st press – high speed (**icon rotates fast**)
- 2nd press – turns off

PUMP AUTOMATIC TIME-OUT

- High speed** – 15 minutes

LIGHT FUNCTION

Press this pad to activate the light

- 1st press: rotating colours
- 2nd press: solid blue colour
- 3rd press: solid green colour
- 4th press: solid red colour

LIGHT AUTOMATIC TIME-OUT

- Time out** – 60 minutes

SETTINGS KEY

From the home page you can access the Settings, where you will find:

- Water Care
- Audio (optional)
- In.clear
- Maintenance
- Day & Time
- Keypad Settings
- Wi-Fi (optional)
- Electrical Configuration
- Factory Reset
- About



Use the arrow keys to move up and down in the list. To select an option, press the lit button beside it (Light button).

At any point you can press the Settings button to return to the home screen.



WATER CARE

The Water Care section will help you set up your ideal filtration and heating settings. Choose from Away, Beginner, Energy Savings, Super Energy Savings and Weekender, depending on your needs.

Use the Light key to choose your setting. A checkmark will appear on the selected icon to confirm.



In Energy Savings mode, the set point will be reduced by 20°F, which means that the heating system will not be engaged unless the temperature falls to 20°F below the spa's set temperature.



Water Care Modes:

Away:



In this mode the spa will always be in economy; the set point will be reduced by 20°F and the filtration can be reduced.

Beginner:

The spa will never be in economy mode, and will run a normal 24 hours of filtration a day.

Energy Savings:

The spa will be in economy mode during the peak hours of the day and resume normal mode on the weekend.

Super Energy Savings:

The spa will always be in economy mode during peak hours, every day of the week.

Weekender:

The spa will be in economy mode from Monday to Friday, and will run normally on the weekend.

MODIFYING SCHEDULES



To see and / or modify the Water Care category, use the lit button to the right (Jet 1) to open the selected Water Care menu.

Use the arrow keys to choose a schedule to modify (choice of economy and filtration schedules). Use the Light key to move between parameters.

You have several possibilities for the schedule (Mon-Fri, weekend, every day, or single days). The schedules will be repeated every week. The time and duration are set in 30 minute increments. Once you have set the schedule, use Jet 1 key to go back. Ensure that you have selected the desired Water Care option in the main Water Care menu.

The filtration schedule shown on the screen will apply to the main filtration pump. Your spa uses a circulation pump configured to run 24 hours by default and the screen will show you the purge setting instead of filtration. The purges are pre-programmed for a fixed number of minutes, therefore the duration will be set to N/A on the screen, and only the start time can be modified.

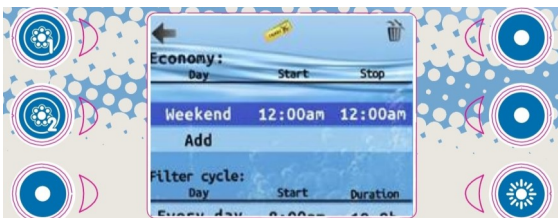

FILTERING

Your spa is equipped with a circulation pump that filters your water for 24 hours a day. If the water temperature exceeds the set temperature by 3 degrees then this pump will shut off automatically until the temperature drops below the set point by approximately 1.5 degrees.

AUDIO (optional)

The Audio section in the Settings menu gives you the option to disconnect or unpair your Bluetooth enabled device.



IN.CLEAR (optional)

The in.k862 keypad can be used with the in.clear sanitization system. If you have ordered this option please refer to the separate instruction



manual provided.

MAINTENANCE

From the Settings page you can access the Maintenance Menu, which gives you access to the following options:



- Maintenance reminders
- Standby
- Error log

MAINTENANCE REMINDERS

The in.k862 keypad will remind you of maintenance required on your spa, like rinsing or cleaning the filter. Each task has its own duration, based on normal use.

The Maintenance Reminders menu allows you to verify the time left before maintenance is required, as well as to reset the time once a task is completed.

Use the UP and DOWN keys to move through the list.

To reset a task, select it by pressing Pump 2, then confirm when prompted. Once you have confirmed the task will be reset.



STANDBY

The Standby mode allows you to service your spa. Pumps will stop for 30 minutes, and automatically restart after this time.

Once Standby mode has been activated a screen will appear to show the pumps are stopped. The normal spa page will return at the end of the maintenance.

Press on the Confirm key to leave Standby mode and restart the spa.

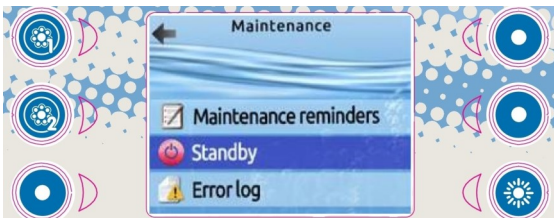

ERROR LOG

In this section you can see errors that have been archived by the system. Use the UP and DOWN keys to move through the list. Errors are archived chronologically, from most recent to oldest (top to bottom).

The Error log page shows the error code, the date of the error and the time.

To see more details on an error select it with the Pump 2 key. A screen will appear with more information on the selected error.

To clear the Error log page press the Select Key and confirm when prompted. The page will be cleared.

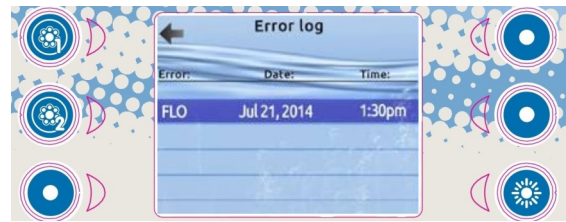

DATE

AND TIME

Here you can adjust the time format, change the year, date and time. Use the arrows to choose the setting you want to adjust and select it by pressing Pump 2.

Use the arrow keys to change the parameters and Pump 2 to move between parameters. Pump 1 will take you back to the main Settings menu.



KEYPAD SETTINGS

In this section you can change the temperature unit and language. Use the arrow keys and move to the setting that you would like to change. Use the Light key to choose and the arrow keys to modify

For the temperature setting you have a choice between Fahrenheit or Celsius.

For the language setting you have a choice between English and French.

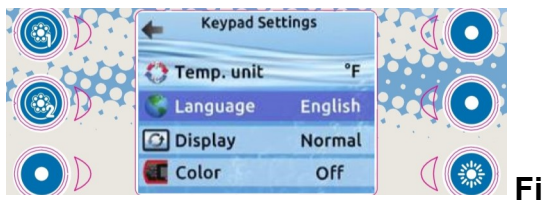

Wi-Fi (optional)

For the Wi-Fi menu to appear in the Settings menu your I-Command module must be equipped with software version 11.00 or higher. This menu allows you to connect your I-Command module to a Wi-Fi network or to change its network.

To connect your I-Command module to a wireless network, use the UP and DOWN keys to go to the Wi-Fi option in the Settings menu and Pump 2 to select it.

After a few seconds the available networks will appear on the screen, as well as their signal strength.

Use the UP and DOWN keys to move through the list. Select your network by pressing the Pump 2 key.

If the Wi-Fi network is password protected enter it when prompted. If no password is required it will connect automatically.

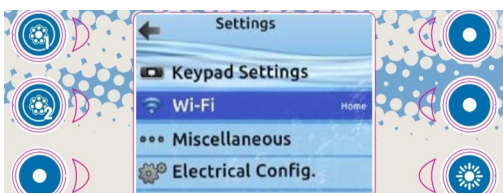

ELECTRICAL CONFIGURATION

Please do not make changes in this section unless you are a qualified electrician.

FACTORY RESET

In this section you can see errors that have been archived by the system. Use the UP and DOWN keys to move through the list. Errors are archived chronologically, from most recent to oldest (top to bottom).

ABOUT

This section shows information about the keypad software number and the revision numbers of the different components of your system.

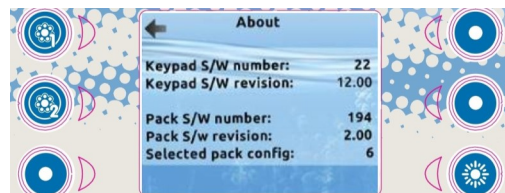

PURGE CYCLES

The purge cycles are programmed to begin at the start of each filter cycle. Pump 2 activates for 1 minute, shuts off and then Pump 1 activates for 1 minute then shuts off.

SMART WINTER MODE

Smart Winter Mode protects your system from the cold by turning the pumps on several times a day to prevent water from freezing in the pipes. The Smart Winter Mode indicator turns on when in this mode of operation. If the temperature drops to 4°C (39°F) within the heater chamber, the system automatically activates the pump to provide freeze protection. The pump will operate until the temperature reaches 5°C (41°F) before returning to normal system mode.

COOLING DOWN

After heating the spa water to the desired set point, the heater is turned off, but the filtration pump remains on for a certain amount of time to ensure adequate cooling of the heating element in order to prolong the useful life of the heater. The heater icon flashes during this time.

For HELP, call La-Z-Boy® Spas at 1.800.465.2933.

STANDBY MODE



A press of the **SETTINGS** key brings you into the menu options. Use the **UP** and **DOWN** arrow keys to highlight **STANDBY**. Press the **LIGHT** key and the following message will appear.

“All pumps off! Press Drain to drain spa”

This mode allows you to stop all outputs including all automatic functions such as a filter cycle, heating requests and smart winter mode purging for 30 minutes to perform quick spa maintenance.

DRAIN MODE

If you wish to put your spa into “**DRAIN MODE**” press the **FUNCTION** key beside the word “**Drain**” on the display. Once you do that the display will indicate “**Drain in progress**”. The filtration pump will turn on and run for 60 minutes.

In order to exit this mode, press the **FUNCTION** key beside the back arrow once to exit **DRAIN MODE**. This will put you back into **STANDBY MODE** and if you wish to exit that press the same key to go back to the main screen.

AQUACOUSTICS SURROUND SOUND STEREO

The built-in AquaCoustics Surround Sound Stereo system (if equipped) accepts the input of most MP3 players that are compatible with a TRS connector (tip, ring, sleeve) also called an audio jack, phone jack, phone plug, jack plug, stereo plug, mini-jack, mini-stereo, or headphone jack.

DOCKING YOUR AUDIO DEVICE

The Docking Station is compatible with all alternate audio sources such as IPOD, USB and MP3 players.

To install any audio device:

- 1 Locate and open the Docking Station door by gently pulling upward on the handle.
- 2 Remove the connector cover prior to plugging in your audio source. Always keep the cover on when the docking station is not in use.
- 3 Center the device over the Docking Station Adaptor and connect.
- 4 Close the Docking Station door once you have begun using your device.



Figure 10 - Audio Tray

Audio source placement in pop out tray (device not included)

AQUACOUSTICS SURROUND SOUND STEREO RECEIVER

FRONT PANEL LAYOUT

- | | |
|--------------------|---|
| POWER | Power On/Off button (once powered on, a long press of the power button results in power off. A quick press of the power button results in a "MUTE" function.) |
| VOL+ | VOL + Volume Increase Button |
| VOL - | VOL - Volume Decrease Button |
| MODE | Mode Button |
| DOWN ARROW | Track Down Button |
| UP ARROW | Track Up Button |
| BAND > | Use the > portion to Play/Pause the USB stick function. |



TRS Connector



RADIO OPERATION

Press BAND button to access FM and AM.

Use the up and down arrow buttons to tune up and down. Long press each button to access manual seek mode, allowing you to go up or down the frequency scale one odd digit at a time.

AQUACOUSTICS SURROUND SOUND STEREO (CONTINUED)

USB OPERATION MODE (note– USB slot for USB sticks only)

For play of other brands of media, please use the auxiliary input.

- A. Insert a USB stick into the USB slot. Songs must be in mp3 or wma format.
- B. Press the up or down arrows for track up/down respectively.
- C. Press >|| button to pause the current track; press >|| again to resume the track.
- D. A long press of the up or down arrows will reverse and fast forward the current track respectively.
- E. Once you exit the spa, always remove the USB stick from the USB port so as to prevent damage to the stick.

AUXILIARY INPUT MODE

- A. Press the **MODE** button until “**AUX**” appears on the LCD screen.
- B. The use of auxiliary mode allows you to play the portable music device though the headphone jack. In order to accomplish this, an auxiliary adaptor must be used.

BASS, TREBLE, BALANCE, FADER, LOUD, EQUALIZER, AREA TUNING

- A. To adjust bass, treble, balance and fader, long press the **MODE** button until the **BAS** feature appears. If you want to change the bass then use the **VOL +** or **VOL -** button. To adjust the treble, balance, and fader setting, long press the **MODE** button until the **BAS** feature appears, then quickly press the **MODE** button until **TRE** appears. Repeat this step for balance (**BAL**), and fader (**FAD**). Adjust with the **VOL +** or **VOL -** buttons.
- B. To enter **LOUD** mode, long press the **MODE** button until **BAS** appears, then quickly press the mode button until **LOUD** appears. Adjust to either ON or OFF using the **VOL +** or **VOL -** buttons.
- C. To enter a specific equalizer setting, long press the **MODE** button until **BAS** appears, then quickly press the **MODE** button until **EQ** appears. Use the **VOL +** or **VOL -** buttons to adjust (options include FLAT, CLASSIC, POP, ROCK or EQ OFF).
- D. To enter **AREA** tuning mode, long press the **MODE** button until **BAS** appears, then quickly press the **MODE** button until **AREA** appears. Use the **VOL +** or **VOL -** to designate between US and European frequency.

CLOCK ADJUSTMENT

Clock display and adjustment: Long press the **BAND** button until the time displays. While the time is displayed, long press the **BAND** button again until the hour is flashing. Then adjust the hour with the volume buttons. Once the hour is set, quick press the **BAND** button again until the minutes are flashing then adjust with the volume buttons. The new time setting will be accepted automatically.

OPTIONAL I-COMMAND SYSTEM

The Smart Phone App that is designed as a wireless hot tub control which allows you to pick the water care settings that fit your schedule. Adjust filtration and temperature settings and create the ideal hot tub experience from inside your home. This option is supported by your iPhone®, iPod touch®, iPad® and Android smartphones. Please contact your local retailer for more information.

If your hot tub comes with this option installed, you need to activate the App Store Icon from your IPOD menu. Type in “**in.touch Gecko**” into the search field to find the application (**Gecko Home or World Editions**) and download from iTunes using your user name and password.

The in.touch world edition allows you to use the Internet anywhere in the world to control your spa.

The in.touch home edition allows you to control your spa using your home WiFi network.

1. Go to the Wi-Fi Networks screen by touching the Settings Icon. The network named in.touch should appear on the list.
2. Press on it to select the in.touch network. Once you've selected it, wait until the WiFi icon appears on the top left corner of the screen. This icon shows that your iDevice is now connected to the network.
3. You can now start the application by finding the icon for the in.touch application and tapping to open it.
4. The first time you use the app a message will tell you to add a spa to your list. You must add your hot tub to the list in order to configure it and use it with the application. Once you tap Ok, you will see a list of visible hot tubs. Tap on yours. Name it when prompted. (NOTE: Both your hot tub and your iDevice must be in range of your home WiFi System to ensure proper operation).
5. Go to Settings in the in.touch app and select WiFi Connection. Choose the network you want your spa to connect to (i.e. your home WiFi). If the network has a security key, enter it when prompted.
6. Home Network - Go to the WiFi settings section on your device and choose the same network.
7. Internet (World Edition only) - Once your spa is connected to the internet, you can use your in.touch world edition any time your device is also connected to the internet, even if you are away from home. The green icon with the word “Linked” beside it will appear at the top righthand corner of the My Spas page to confirm your connection.



COLOR COORDINATED COVER

Place the Color Coordinated Cover on your spa / hot tub. Keeping the cover in place anytime the spa / hot tub is not in use reduces the heating time, minimizes operating costs and prevents acrylic damage due to UV overexposure. The time required for initial heat-up varies depending on the starting water temperature, ambient temperature, and the capacity of your spa / hot tub.

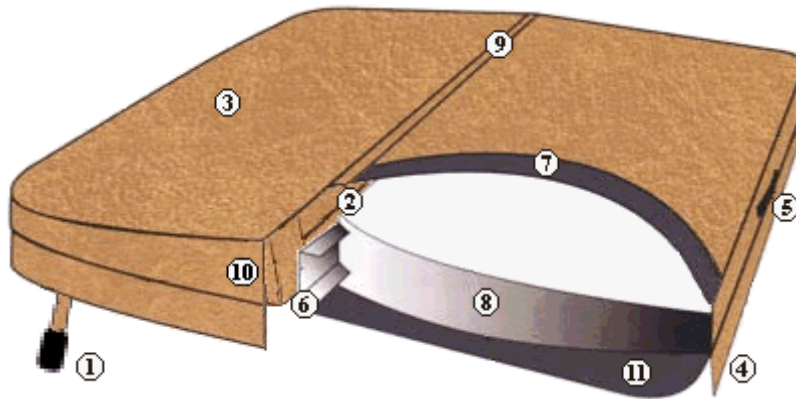

Figure 11 - Feature Callouts

- | | |
|--------------------------------|-------------------------------------|
| 1. Lock-down tab | 8. Chemical-resistant vapor barrier |
| 2. Double-stitched seams | 9. Polystyrene seam stoppers |
| 3. Marine-grade cover material | 10. Reinforced edges |
| 4. Edge overlap material | 11. Breathable underside material |
| 5. Grip handle | |
| 6. Aluminum channel | |
| 7. Heat-sealed insulation | |

Use the lock-down tabs to prevent access to the spa / hot tub by children and to prevent the wind from lifting the cover off.



Sitting, standing, and snow buildup on the cover will break the cover. Dragging it over rough surfaces will scuff or tear the fabric. Always lift by the handles or use the optional cover lift device.

WATER MANAGEMENT

All La-Z-Boy® Signature Spas are equipped with an Ozone Purifier that is highly effective in removing unwanted contaminants from the water by means of an electronic oxidation process. If your water quality seems improper, increasing the time your spa filters the water may clear up your problem.



Below are some answers to common water chemistry questions.

pH	It is common to have pH fluctuations after adding chemicals to your spa / hot tub or after a party. Let your jets run and give your water time to stabilize. 9 times out of 10, your pH will come back into the 7.2 - 7.8 range on its own.
Mildew on cover	Mildew usually grows in the folds and seams of your cover and then drips into your spa / hot tub water causing cloudiness and/or odor. Clean with a non-foaming spa / hot tub cover cleaner and then rinse the inside of your cover with clean warm water.
Foamy water	Foam typically results from soap residue on your skin and hair, or laundry detergent residue on clothing. Take a soapless shower and rinse all clothing in warm water prior to bathing.
CLEAR green or brown water	Your "source water" most likely has dissolved heavy metals. When this is the case, use a respected brand of demineralizer found at any local pool/ spa store. Using a pre-filter can remove these contaminants before they get into your spa.
CLOUDY white water	Although a normal condition immediately after filling that dissipates after time, with stabilized water this is a visual indication that the total alkalinity or pH or both are at improper levels. Test your water weekly and maintain proper water chemistry.
CLOUDY green water	Algae can be resolved by adding a respected brand of algaecide.
Odor and/or cloudy water	If your water develops an odor and/or cloudiness, clean your cover and filters and try increasing the amount of time your spa filters per day by turning your filtration cycle time or duration up.
Scaling	A visual indication that the total alkalinity or pH or both are at improper levels. Test your water weekly and maintain proper water chemistry.

Frequently Asked Questions

Why Does the Circulation Pump run all the Time?

Your spa / hot tub is programmed for constant filtration to keep your water as clean and clear as possible. It is normal for your circulation pump to run this way when programmed to do so.

Who do I call for Guarantee Information or Service?

Call your local dealer. Please note, you must register your spa / hot tub within 30 days of purchasing your spa / hot tub.

Who are the Service Companies in my area?

Call your local dealer. If you encounter a matter that can't be easily resolved over the phone, a local technician can be dispatched to your home. The service technician may assess reasonable travel charges during on-site repairs.

What Happens when my Guarantee Expires?

Your local dealer will continue to provide service for your spa / hot tub after your guarantee has expired.

How do I adjust my Hydrotherapy jets?

Simply turn each of the hydrotherapy jets counterclockwise to open and clockwise to close. Be careful not to overturn these jets, as damage can occur.

Note: We recommend leaving all hydrotherapy jets fully open to allow the pumps complete control over jet pressure.

CAUTION



Do not turn off too many jets at the same time. This will create backflow and possible damage to your spa / hot tub!

How often should I drain my spa / hot tub?

You should drain and refill your spa / hot tub every 1-3 months depending on usage. Every other time you drain and refill, you should also replace the filters and wipe down the spa.

What is the insulation made of?

Our Thermal Barrier Insulation System includes 4 insulating zones and the Color Coordinated Cover. The plumbing, shell and floor are sealed in a reflective insulated thermal blanket. As an added layer, the same insulated thermal blanket is installed on the backside of the cabinet around the entire perimeter of the spa / hot tub.

How do I use the optional AquaCoustics sound system?



Gain access to the MP3 docking station by pulling the cover out and lift the lid. Most MP3 players that are compatible with a TRS connector can be used with the AquaCoustics Surround Sound System. Your MP3 player should function as normal and the sound should now be heard through the speakers.



How do I bleed air from my system?

When draining and refilling your spa / hot tub, the pump may become air locked. Air-locked pumps stop water from flowing in your spa / hot tub and is easily resolved by bleeding off the trapped air. To do this:

- Turn off the GFCI breaker
- Open the access panel below the topside control panel
- Loosen the union on the circulation pump until you hear the trapped air escape as shown below.
- Once water drips out in a continuous stream, hand tighten the union until the water stops leaking
- Turn on all pumps to make sure that there are no leaks
- Put the access panels back on
- Turn on the GFCI breaker



Figure 12 - Bleeding Air

How should I clean my spa?

Use non-sudsing cleaners and non-oily polishes. A high quality all purpose cleaner quickly removes scum lines and helps restore your shell's original beauty. Rinse all filters, covers, pillows, and surfaces thoroughly with warm tap water. A high quality filter cleaner is a safe, effective way to clean and re-use your filters and a plumbing cleaner cleans the inside of all plumbing in your spa / hot tub. You can contact your local La-Z-Boy Spa dealer to order these easy-to-use cleaning products.

TROUBLESHOOTING

If a problem arises, you can check this list for a quick solution. If this does not resolve your problem, please call your local dealer for servicing information.

Important: Most problems can be quickly resolved by resetting the GFCI breaker. Try this first before proceeding.

Problem	Cause	Solution
Breaker trips	Wiring error	Spa Neutral wire not connected to GFCI (connected to Neutral bus)
	Wrong GFCI	GFCI breaker is wrong size or type
Chlorine level changed suddenly	Ultraviolet radiation (sunlight)	Spa is located in direct sun and ultraviolet radiation destroys free chlorine.
Circulation pump not running in constant filtration mode	Temperature limit reached	This is normal. When the water temperature is 2°F over the set point and warmer than 95°F, the pump automatically turns OFF in constant filtration mode to prevent overheating the water. The pump could also be programmed to run less than 24 hours.
	Dirty filters	Thoroughly clean filters. If problem persists, oils may have accumulated in the spa. Flush and rinse plumbing. Drain tub and thoroughly clean shell.
Foamy water	Soaps, skin oils, or undissolved sanitizer particles	Close the air control valves and allow filtration cycle to run
		Add defoamer
		Drain and clean spa
		Clean or change filters
Light doesn't work	LED burnt out	Change LED
	Loose wire	Reconnect wire
	Loose plug	Reconnect plug
Leak	Loose connection	Check and hand-tighten unions at heater & pumps, or clamps on jets
	Drain open	Close drain valve or replace cap

For HELP, call La-Z-Boy® Spas at 1.800.465.2933.

Problem	Cause	Solution
Low/no jet pressure	Air lock	Bleed air from the system
	Dirty filter	Check and clean or replace filter
	Closed jets	Open all jets by turning CCW
	Closed valves	Open all gate valve shutoff valves on heater and pumps
	Low water	Fill spa 1" above all jets (excluding neck jets)
Moved my spa and now it doesn't work	Wiring error at GFCI	Check Neutral wiring of GFCI
	No power to spa	Reset circuit breakers on GFCI panel and main circuit breaker panel
No flow	Closed jets	Open jets
Nothing works	Breaker has tripped	Check and reset breaker. If problem persists, check for loose electrical connections. Check for Neutral wiring error at GFCI.
pH changed suddenly	Total alkalinity	Check total alkalinity level and adjust if necessary.
Pump not running	No power to spa	Reset circuit breakers on GFCI panel and main circuit breaker panel
Pump runs continuous	Normal	Normal
Sanitation (level too high/low)	Improper level for use	Adjust level for use
Water too murky	Improper filter cycle time	Increase filter cycle time
Scaling	Hardness level	Adjust hardness level
Water too hot	High set temperature	Turn down set temperature on topside control panel
	High ambient temperature	Remove the cover from the spa
Water will not heat	Thermostat set too low	Check and reset to desired temperature
	Air open	Close air control valve
	Dirty filter	Check and clean filter
	Blown fuse	Check and replace fuse
	Valve closed	Check and open all valves
	Cover off	Put cover back on spa

ERROR CODES

Message	Meaning	Action Required
	No message on display. Power has been cut off to the spa.	The control panel will be disabled until power returns. Spa settings will be preserved until next power up.
- -	Temperature unknown.	After the pump has been running for 2 minutes, the current water temperature will be displayed.
Hr	An internal hardware error has been detected.	Restart the spa pack and start & stop all pumps and blowers. If the error reappears, replace the spa pack.
Prr	The “Prr” error message indicates a problem with the regulation probe. The system is constantly verifying if the temperature probe reading is within normal limits.	Verify if the regulation probe is properly connected. Replace the heater if the problem persists. Replace the spa pack if the problem persists.
HL	The water temperature at the heater has reached 119F. Do not enter the spa water.	Measure the water temperature and compare the reading. Check for flow obstructions. Call for service.
FLO	The system did not detect any water flow while the circulation pump was running.	Make sure water valves are open. Check the filter for blockages. Make sure there are no air locks in the system.
UPL	No low level configuration software has been downloaded into the system.	Call for service to upload the programming software.
AOH	Temperature inside the spa skirt is too high, causing the internal temperature to increase above normal limits.	Make sure vents are open and operational.
OH	Water temperature in the spa has reached 108F. Do not enter spa water.	Measure the water temperature and compare the reading. Remove the cover and let the spa cool down. Add cold water and lower the filter cycle durations.

MAINTENANCE AND CARE

Important: The guarantee on your spa / hot tub and equipment depends on proper water balance. In addition, the following maintenance procedures must be followed periodically.

DURACARE AND OPTIONAL EVERLAST CABINETS

The spa / hot tub consists of a rigid polymer that combines the durability of plastic with the beauty of a wood-looking cabinet. To clean the cabinet, a mild soap and water solution easily removes residue.

These Everlast cabinets utilize a magnetic latching system to fasten and hold the exterior panels in place. In order to remove a panel for access you need to start at the lower right hand corner of the panel and disengage the first magnetic latch by pulling the panel forward enough to allow your hand to get behind the panel. Once you have done that you can run your hand behind the panel to disengage the other magnetic latches and be able to remove the panel completely.

To reinstall the panel, line the panel up in the opening and lift it in place and the magnetic latches will engage with the panel so you can shift it place and complete the reinstallation.

COLOR COORDINATED COVER

1. The heat shield cover on your spa / hot tub is made from a weatherproof marine-grade vinyl. Your cover will last much longer if you heed the following suggestions:
2. Don't drag your cover on the ground; wearing of the vinyl could easily develop into a tear.
3. The insulating foam in your cover is not designed to hold the weight of a person or an animal.

Important – Cracked foam in a cover is not covered under the Guarantee. Do not stand on it.

4. Occasionally clean the inside of your cover with a spa / hot tub cover cleaner and rinse with warm water. (Using soap or vinyl cleaners on the inside of your cover causes foamy water.) Call your local dealer to order spa / hot tub cover cleaner.
5. A spa / hot tub cover cleaner applied to the outside of your cover and stitching once yearly will keep it looking better longer. Call your local dealer to order vinyl cover cleaner.
6. Do not lift your cover by the safety straps, they are made to secure the cover to the cabinet and may tear.

DRAINING AND REFILLING YOUR SPA



Figure 13 - Drain Operation

1. **Turn Power Off** - turn the power off at the spa consoles and deactivate disconnect switches at the GFCI plug or load center.
2. **Locate Spa Drain Valve** - The spa drain valve is located on the side of the cabinet.
3. **Remove Drain Valve Safety Cap** - Pull the drain valve completely out. Remove the safety drain cap and store for use when refilling your spa. Attach a standard garden hose to the drain valve.
4. **Attach Hose & Drain** - With the garden hose attached push the drain valve in so that the hose is flush with the drain. To stop draining the tub simply reverse the process by pulling the drain completely out, installing the drain valve cap and pushing the drain in fully. Make sure you do not force the drain in so that it is properly aligned.

FILTERS

The dual micro filters in your spa / hot tub should be removed and cleaned every week with a high quality filter cleanser and typically replaced every 4-6 months (depending upon use). You can clean your filters with the water pressure from the end of a garden hose then rinsed with warm water. This ensures that the water is being filtered properly.

DO NOT USE BLEACH. We recommend having replacement filters on hand that can be swapped between cleanings. Doing so enables you to quickly exchange the dirty filters with the clean ones and immediately start your spa / hot tub again. Call your local dealer to order replacement filters and filter cleaner.

For HELP, call La-Z-Boy® Spas at 1.800.465.2933.

ALL ACTIVE COMFORT MASSAGE JETS

Remove and clean the jets as needed using a high quality plumbing cleanser, water, and a cloth or soft-bristled brush.

LED MOOD AND SAFETY LIGHTS

Drain the spa / hot tub and clean the LED Safety and Mood Light lens as needed using an optical cloth and an eyewear cleaning product specifically designed not to scratch optical surfaces.

If the back side of this lens is also dirty remove the rear panel, twist the light assembly counterclockwise to remove the light from its holder, and clean in this same manner.

SURFACE

The acrylic surface of your spa / hot tub should be cleaned with a high quality all purpose cleaner and thoroughly rinsed with warm (not cold) water before refilling.

WARNING



Cleaning your spa shell with abrasive cleaners could discolor, dull, or dissolve the acrylic surface and will void your shell warranty. **NEVER** use paint solvents, acids, acetone, benzene, lacquer thinner, toluene, xylene, or similar chemicals to clean your spa shell.

WATER

Depending on usage, the water in your spa / hot tub should be changed every 1-3 months. Upon each change of water it is a good practice to wipe down your spa.

SHUTDOWN / WINTERIZING



In the event that you do not wish to use your hot tub year-round, it is very important that you properly winterize to protect against damage from freezing. Your **La-Z-Boy® Spas** retailer can perform this service for a nominal fee. If you choose to winterize your hot tub yourself, please follow the directions outlined below:

- Drain the hot tub entirely see section - **DRAINING AND REFILLING YOUR SPA**
- Remove and clean the cartridge filter element see section - **FILTERS**
- Using a wet/dry utility vacuum, remove remaining water from the jet openings, filter cartridge housing, and footwell.
- Either pour or use a turkey-baster where necessary to add potable biodegradable RV antifreeze to areas such as pump wet end, jet channels, filter housing, blower channels. **DO NOT USE AUTOMOTIVE ANTIFREEZE.**

- **Important:** mixing potable biodegradable RV antifreeze with water significantly reduces its ability to protect against freezing. Therefore, it is very important ALL water is removed from the hot tub plumbing before adding.
- Turn pump on for only a few seconds to circulate the antifreeze.
- Unthread and disconnect all unions in the support equipment area. Remove lowest winter drain plug on pump face plate. Repeat for all pumps, where applicable.
- Cover exposed plumbing connections with plastic bags and duct tape.
- Where practical, disconnect hot tub support equipment and store in a dry heated area.
- Install the safety hardcover, and cover the entire hot tub with a tarp to prevent premature weathering of the cabinet and the safety hard cover.
- Remove snow build up regularly to prevent damage to the safety hard cover.
- It is assumed that your **La-Z-Boy® spas** hot tub has been properly installed on a reinforced concrete pad to eliminate lifting of the hot tub due to hydrostatic ground water pressure.

We highly recommend that you have a spa / hot tub professional winterize and restart your spa / hot tub.

WARNING



Damage from improperly winterizing or restarting your spa / hot tub is not covered under your warranty. You can call your local dealer to assist you in properly winterizing your spa / hot tub.

GLOSSARY

Drain Bib	A male garden-hose-style fitting to which a garden hose is connected for draining water.
GFCI	Ground Fault Circuit Interrupter. A special type of circuit breaker designed to shut power off if there is a leak of electricity detected in the equipment.
Ionizer	See <i>Ozonator</i> .
Jet, Hydrotherapy	A plumbing device that directs pressurized air and/or water to desired areas of a spa / hot tub.
Ozone (O₃)	Produced by an Ozonator, Ozone is a form of oxygen (O ₂) and is a powerful oxidizing agent. Ozone destroys organic waste and byproducts and helps in the control of algae and bacteria. Ozone is not a stand-alone sanitizer.
Ozonator	An electronic unit designed to purify and destroy algae, bacteria, mold, and viruses while prolonging equipment life.
pH	The scientific scale for measuring Hydrogen Ion concentration (0 to 14) that shows the acid/alkaline content in water.
Pump	The electrical component that keeps water moving throughout the entire circulation system.
Sanitizer	A water additive that works with your Ozonator to help remove harmful elements in your spa water.
Spa Pack	The main control box that operates the electrical systems within the spa / hot tub.
TA	See Total Alkalinity
TDS	See Total Dissolved Solids.
Topside Control	The user-interface panel that connects to the control box and controls various spa / hot tub functions such as jet pumps and heater.
Total Alkalinity (TA)	A measure of how much of the alkaline substances there are in the water (recommended 80 - 120 ppm).
Total Dissolved Solids (TDS)	A measure of all of the materials that are dissolved in water. The higher this number, the more materials are dissolved in your water.

